



Steeple News

2011

August



Thanks for Giving
The Gift of Life



Pastor's Page



A young reporter wanted to get a feel for agriculture, so he called upon a farmer and said, "How's your wheat coming along?"

The farmer replied, "I didn't plant any."

"Really?" asked the reporter. "I thought this was supposed to be wheat country."

"Some say it is," came the reply. "But I was afraid we might not see enough rain this year."

"Well, what about your corn. How is it doing?" the young man inquired.

"Didn't plant corn this year," the farmer said. "I was afraid of corn blight."

"Alfalfa?"

"Nope. Afraid the price might drop."

"Well, then," asked the reporter, "what did you plant?"

"Nothin'," the farmer said. "I just played it safe."

Does it ever occur to us that our fears and worry often paralyze us and leave us powerless to move in any direction? How many of us "just play it safe" and never venture out to accomplish even basic tasks, much less monumental achievements? I can remember back when audio-visual aids in the church consisted of chalkboards and flannel graphs. The church I was serving had received a bequest from a long time member who had recently died.

One night we were discussing the possibilities of using the bequest to purchase a television monitor and VCR to use in the education building. After some discussion, one elder was dead set against it. We asked him if he thought it was unbiblical or unethical to use that sort of technology. The elder responded by saying, "If we buy electronic equipment, someone might break into the church and steal it."

The rest of us sat there bewildered. If we were to follow that logic we could say we can't buy a silver communion set because someone might steal it. Or we could say we can't purchase a sound system for the sanctuary because someone might steal it. Or we can't put in a stained glass window because someone might throw a rock through it. Or we can't minister to the neighborhood because someone might sue us. And the list can go on.

Of course, no one needs to take unnecessary risks, yet no person, organization or nation ever became successful by "playing it safe." If the founders of our nation played it safe there would have been continued tyranny and no democracy for a hundred more years. If Microsoft Corporation hadn't taken some risks it would have been swallowed up by a second-rate electronics firm. If Jesus of Nazareth had played it safe and decided not to go to the cross we'd still be carving wooden statues and praying to the sun and moon.

Henry David Thoreau once wrote: "If you have built castles in the air, your work need not be lost; that is where they should be. Now put foundations under them."

This week why don't you take a little walk on the wild side? It'll do your heart good.

Your interim pastor and sometimes risk-taker, Gary Proietti

Remember in Prayer

The family of Mike Prout, the family of Virginia Woodard, Lawrence and Evelyn Johns' nephew, Carleigh Dufresne, Wayne Lutes, Tom and Jackie Holland, Jean and Jim Nichols, George Hoag, Jackie Heckleman Pettit, Jamie Myers, Matt Casket, Barb Brunow, Judy Shover, Beth Statzer, people battling cancer, our local, state and federal government officials, and all God's children suffering through disasters.



Thank You

Thanks to Dan Pogacsnik, Linda Phillips, Pauline Malone and Pastor Gary for the time and effort they have given to secure funding for the Erie County Boys and Girls Club held at the Berlin Heights Community Center. Lorain County Boys and Girls Club have offered to help. Arrangements need to be finalized soon. For those interested in this mission contact Pastor Gary or Linda Phillips.

Thanks to Bob Bement for removing a bat that was found exhausted in our church on June 15. The bat was taken outside and hopefully will not return. Although the church belfry is a perfect home for our flying friends.

A grateful thank you to everyone who has volunteered to keep the Angel Food mission going. This month eight families ordered 19 boxes. Did you know that half our orders come from the internet? Thanks for saying "yes".

—Women's Fellowship



Point of Light Missions

The mulch is here and spread! **We want to thank the Boy Scouts and all those who helped** at the playground spread that mountain of mulch on Saturday, July 9. With so many hands the job went quickly. Also, a big **thank you to Ron Nealy** who donated the black mulch that is around the tree. Check it out, the area looks great!

We are now taking donations for the rummage sale that will take place during the Basket Festival, August 6 & 7. Items should be clean, in good condition / good working order. **Please no clothing.** Again this year will be a "Parade of Baskets" raffle. Tickets will be sold during the rummage sale and the winners will be drawn at the conclusion of the festival. Workers are needed to help with the sale on Saturday and Sunday. If you have an hour or two to help that would be great! Talk to Becky Coleman to sign up for a time. The profits from this sale will benefit the church's general fund and the Berlin Heights Community Center.

Call Bob Bement at 440-935-1067 (cell phone) to pick up your donations.

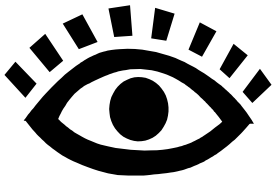

Point of Light Missions is always looking for people that are interested in mission work. New ideas are always welcome.

Please join us if you would like to get involved with this group. We meet the third Monday of the month at 7:00.

—Point of Light

Lectionary Sunday Scripture:

Weekly Theme: Face to Face",

Nineteenth Sunday in Ordinary Time, 8/7/2011, TRUE, "1 Kings 19:9-18 Genesis 37:1-4, 12-28

Psalm 85:8-13

Psalm 105:1-6, 16-22, 45b

Romans 10:5-15 Romans 10:5-15

Matthew 14:22-33 Matthew 14:22-33

Weekly Theme: When All Seems Lost",

Twentieth Sunday in Ordinary Time, 8/14/2011, TRUE, "Isaiah 56:1, 6-8 Genesis 45:1-15

Psalm 67 Psalm 133

Romans 11:1-2a, 29-32 Romans 11:1-2a, 29-32

Matthew 15:[10-20] 21-28 Matthew 15:[10-20] 21-28

Weekly Theme: Bold Moves"

Twenty-first Sunday in Ordinary Time, 8/21/2011, TRUE, "Isaiah 51:1-6 Exodus 1:8—2:10

Psalm 138 Psalm 124

Romans 12:1-8 Romans 12:1-8

Matthew 16:13-20 Matthew 16:13-20

Weekly Theme: Be Transformed",

Twenty-second Sunday in Ordinary Time, 8/28/2011, TRUE, "Jeremiah 15:15-21 Exodus 3:1-15

Psalm 26:1-8 Psalm 105:1-6, 23-26, 45b

Romans 12:9-21 Romans 12:9-21

Matthew 16:21-28 Matthew 16:21-28

—Diaconate

Looking into scheduling another Blood Drive between
Thanksgiving and Christmas.

—Christian Enlistment

—Women's Fellowship



Thanks

to

All

Who

Gave

Their

Time

To the

Blood

Drive.



Pauline Malone at the registration desk for the blood drive.



Pastor Gary preparing to give.



Sandy Shively giving the gift of life.



Evelyn Johns serving the refreshments.



The American Red Cross blood drive held July 15th was a success thanks to those who participated from our congregation— Becky Coleman, Sandy Shively, Rev. Gary Proietti, Hollie Beatty, Bob Bement, Marianne Snyder, Brad Phillips, Mary Van Benschoten, and Andy Keller as well as 17 life savers from the community. Twenty six responded to the call and 22 units of blood were collected.

What a great mission....the gift of life!

Let's all say "Amen" to that!

P.S. Thanks to Pauline Malone and Bob Bement for helping with registration and Evelyn Johns, Becky Coleman, Pauline Malone and Barb Bement for cookies and fruit. Also to Evelyn and Barb for serving refreshments.

What we have learned about blood donations?

American Red Cross Blood Donation

- Eligibility depends on the type of cancer and treatment history. If you had leukemia or lymphoma, including Hodgkin's Disease and other cancers of the blood, you are not eligible to donate. Other types of cancer are acceptable if the cancer has been treated successfully and it has been more than 12 months since treatment was completed and there has been no cancer recurrence in this time. Lower risk in-situ cancers including squamous or basal cell cancers of the skin that have been completely removed do not require a 12 month waiting period.
- Diabetics who are well controlled on insulin or oral medications are eligible to donate.
- Wait at least 8 weeks between whole blood (standard) donations.
Wait at least 7 days between platelet (pheresis) donations.
Wait at least 16 weeks between double red cell (automated) donations.
- Age eligibility You must be at least 17 years old to donate to the general blood supply, or 16 years old with parental/guardian consent, if allowed by state law. There is no upper age limit for blood donation as long as you are well with no restrictions or limitations to your activities.
- —www.redcrossblood.org

All human blood may look alike, but you can't donate to just anyone and you can't receive blood from just anyone. Different blood types need to be matched correctly.

Group O can donate red blood cells to anybody. It's the universal donor.

Group A can donate red blood cells to A's and AB's.

Group B can donate red blood cells to B's and AB's.

Group AB can donate to other AB's, but can receive from all others.

Enjoying refreshments
After their parents donated
a unit of blood.





FACTS: When you make a blood donation, you join a very select group. Currently only 3 out of every 100 people in America donate blood.

- Every two seconds someone in the U.S. needs blood.
- More than 38,000 blood donations are needed every day.
- A total of 30 million blood components are transfused each year in the U.S. (2006).
- The average red blood cell transfusion is approximately 3 pints.
- The blood type most often requested by hospitals is Type O.

Fisher –Titus Medical Center—Health Ministry

Let's take a look at the value and blessings of family life this August.

How can healthy families be described? A healthy family has a strong commitment to each other, which includes both adults and children. Without this the family cannot serve as a refuge for each other as God intended it to be. One account of family commitment recorded in the Bible is found in Ruth 1:1-22. The passage describes the loyalty and love of Ruth and her mother-in-law Naomi.

Families also need to relate to one another on an intimate level. God has intended for many of our personal and emotional needs to be met in families. Many family experts have written that only one basic function of the family will persist over time, and contribute to the survival of the family. This one aspect is emotional nurturance of all persons. Not always easy but very important.

Families also need a sense of identity. Parents and children need to feel that they are both an essential part of the family as a whole. Take some time this month and really enjoy it with your family. How lonely are lives would be without family. (taken in part from Season of Wholeness Vol. 1)

“Train up a child in the way he should go, and when he is old he will not depart from it.”

—Proverbs 22:6

—Jill Schafer, RN



Being 5 for 5 is one sign of congregational vitality in UCC churches that fully support **Our Church's Wider Mission**. These leadership churches give to Basic Support and Special Support (all four special mission offerings).

- Neighbors In Need (NIN)
- One Great Hour of Sharing
- Strengthen the Church
- Christmas Fund



Jamming for Jesus

The Christian Band, "Take Heart" invites everyone to join in.



Bring instruments to sit in and play. Bring voices to sit in and sing, or come to listen and praise God at the Christian Center, 930 S. Main St., Huron, Ohio (located at the rear of Zion Lutheran Church).

The jam sessions are on the 2nd Monday of the month, beginning at 7:00 pm. For more information call 419-433-4711 or 419-433-8504. All are welcome.

—Linda Phillips



Women's Fellowship September 6th Meeting

program on "Using Fresh Herbs".

Note the change in our September program. Postcard will be given out. We are going to Mulberry Creek Herb Farm, 3312 Bogart Road, Huron, Ohio for our annual women's guest night with a picnic Salad and Dessert dinner hosted by Women's Fellowship. We invite all area women to come join us

For reservation, please call Pauline Malone at

419-588-2170

—Women's Fellowship

Birthday and Anniversaries

Aug. 1 Wyatt Downing
Aug. 1 Kyle & Chelsey Meagrow
Aug. 2 Pat Carson
Aug. 3 Shane Oehling
Aug. 4 Kathy VanBenschoten
Aug. 4 Alyssa Koelsch
Aug. 4 Piper Ball
Aug. 4 Rianna Dingle
Aug. 5 Evelyn Johns
Aug. 5 Roger & Nancy Wallace
Aug. 5 Jeff & Hollie Beatty
Aug. 6 John Holler
Aug. 7 Tyson Kennedy
Aug. 7 Mike & Ellen Drake
Aug. 7 Dan & Amy Pogacsnik
Aug. 8 Annette Schroer
Aug. 9 Benjamin Shupe
Aug. 9 Tom & Norma Robson
Aug. 10 Renee Robinson
Aug. 11 Allison Soviak
Aug. 16 Tina Wills
Aug. 17 Claude & Wilma Jean Kernell
Aug. 18 Lawrence Johns
Aug. 19 Mike Plunkett
Aug. 20 Mark Malone
Aug. 21 Meghan Stith
Aug. 22 John & Rita Holler
Aug. 22 Ron & Karen Lindner
Aug. 23 Jeffery Ortman
Aug. 25 Todd Mullen
Aug. 26 Madison Gornek
Aug. 26 Kathleen Soviak
Aug. 26 Trisha Kohler
Aug. 27 Eric Robson
Aug. 28 Nathan Hughes
Aug. 28 Misty McDonald
Aug. 29 Bobette Nemire
Aug. 29 Wendy Harper
Aug. 29 Quinn Holler
Aug. 31 Samantha Jamison

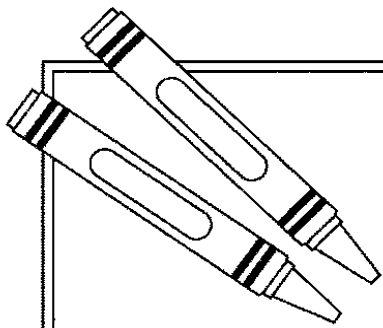

Just for KIDS

Matthew 4:10

Find the words that fit these definitions. You may use a dictionary or check in a church bulletin or hymnal. Write the letters from the words on the lines below.

A song sung in church _____
1 2 3 4

Money given in church _____
5 6 7 8 9 10 11 12

"The Lord's _____"
13 14 15 16 17 18

What we find written in the Bible:
God's _____
19 20 21 22

Another word for Bible verses _____
23 24 25 26 27 28 29 30 31 32

Warm feeling in your heart _____
33 34 35 36

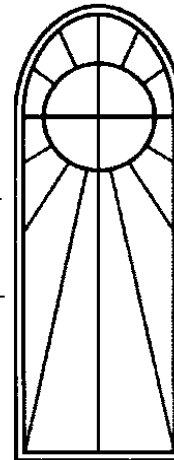

" _____
19 5 9 23 1 10 13 28 1 8

_____ _____ _____
33 5 9 22 2 5 29 9 12 5 22

_____ _____
15 4 22 23 8 9 35 17

_____ _____
5 4 33 2 1 10 3

Matthew 4:10b



**We will continually
praise
God's Holy name.**

**First Congregational Church and Society
United Church of Christ
Reverend Gary Proietti
5 E. Main Street
P.O. Box 66
Berlin Heights, OH 44814
419-588-2102
e-mail address: bhcong@frontier.com**

7/26/2011