

# Steeple News

2011

February





## From the Pastor

An Oregon pastor tells the story of a 13-year-old boy who had been run over by a tractor and had become completely paralyzed except for one arm. Joe was hospitalized long term and was left without speech. A deep depression had waded over him and no one could reach out to him or help him.

After some time Joe was transferred to a pediatric hospital close to his home. He was still immobile and emotionally unresponsive. It seemed his depression had worsened over time. In the same wing of the hospital there was a 2-year-old boy suffering from a brain inflammation and whined for hours at a time. Joe's mother noticed the toddler and had remembered something they had learned from the Center for Attitudinal Healing; "IF YOU CAN HELP SOMEBODY ELSE YOU'RE NOT DISABLED."

After asking the baby's mother for permission, she carried the child over to Joe and laid it on top of him. For a while the baby just lay there, but suddenly Joe took his good arm and began to gently caress the baby. For several minutes the baby cried in Joe's arm, but suddenly the whimpering ceased and the two spent many hours together after that. Both children began to improve and recover, and soon Joe began to talk again and even learned to walk.

Each of us unconsciously believes that we are disabled in one form or another. I sometimes hear people say, "I could never speak in front of a crowd of my peers." Others think they have no viable talent or skills to ever amount to anything in this world. Elderly people want to do something significant for their church, but feel they are too old to be of any good.

Yet, if we can help somebody else, we are not disabled. It doesn't take much effort, but if we could just pray for another person in need, we could succeed in "moving mountains" in Christ's name. It doesn't take a lot of talent to speak a word of encouragement to one who is discouraged and it doesn't take a theologian to share our faith with someone who is searching for truth and direction.

God doesn't call us to be overachievers. Nor are we expected to be world renowned evangelists. It isn't necessary to build great cathedrals or worldwide mission endeavors. We are called only to be faithful – faithful to the call of Christ so that when our lives are weighed in the balances we can hear the words, "Well done, good and faithful servant. Enter in to the joy of the Lord."

Peace and joy,  
Rev. Gary Proietti

**We will continually praise  
God's Holy name,**

## Remember in Prayer

Pat Clemens, boy with eye problem, The Gray family, Carla Bottilier, Amber Harkey, victims of Tucson Massacre, Lindsay Aruskevicius, the family of Monica Rose, Marianne Snyder's friend Amy 's daughter who slipped on the ice and broke her wrist and leg, cousin Nancy as she begins treatment for cancer,



## Thanks and Gratitude

**Marianne Snyder** wants everyone to know that she has a new job and thanks everyone for their prayers.

**Dear Friends,** This is to acknowledge with deep appreciation your donated gift of 8 cartons of canned supplement to Cancer Services.

Your generous donation allows us to continue our mission of assisting local cancer survivors and their families and financial support.

—Cancer Service Sandusky Ohio

**Dear church family,** I want to thank everyone for the cards, prayers and well wishes during my recovery.

—**Connie Deehr**

**Address for Bryan Bittner:**  
is in Afghanistan

1st LT Bryan Bittner  
2nd Bn 3rd Marines  
HQS MT  
Unit 44045  
FPO A T 96607-4045

**Dear Women's Fellowship,** Thank you for the glass star. The one I received has been added to my collection of sun catchers in my windows at the Carriage House. Your thoughtfulness is much appreciated.

**God's Blessings, Ruth Brown**

**Dear Friends,** Thank you so very much for the beautiful star. It's hanging in my window and I'm so enjoying it. May God bless you and your thoughtfulness and caring.

**—Virginia Richard** Carriage House resident

## **Diaconate**

The Diaconate met on January 11, 2011 and appointed various job duties to the committee members. We discussed various topics dealing with our responsibilities.

The bid discussion was how to handle the Coffee Hour sign-up sheet. Suggestions included having the congregation bring items on the first Sunday of every month and having various committees and boards sign up for a Sunday.

If we cannot get members to volunteer coffee and juice will be the only items provided.

Any questions or suggestion contact: William Deehr (419)588-3415  
Chairman of Diaconate

**If any youth seek to serve** the church, we need those in grades 2nd through 8th interested in being an acolyte (an altar attendant in worship). Please call Kirsten Grech at 419-588-2575 for details. Diaconate will soon be putting a schedule together for the year.  
--Kirsten Grech - Diaconate

**GFS.**  
gordon food service

# Marketplace

Open  
To The  
Public

No  
Membership  
Fee

Open  
7 Days a  
Week

Women's Fellowship sponsors FunFunds through Gordon Food Service for churches operating.

Flyers available—fill one out take it to GFS and receive a card for First Congregational UCC #2452290 or go online at [https://gfs.com/fundfunds/homepage? OrgNumber=2452290](https://gfs.com/fundfunds/homepage?OrgNumber=2452290)

—Women's Fellowship

**Huron County General Health District** 180 Milan Ave. Norwalk, Ohio

### **Give Kids A Smile**

- Friday, February 4, 2011
- 12 PM to 4 PM at Huron Co. Health  
180 Milan Ave, Norwalk
- 1:30pm to 3:30pm at  
Willard Middle School 949 S. Main St., Willard, OH
- **By Appointment Only**



Dental Screenings available at no cost  
for children up to 18 years of age.

Provided by Dentists & Hygienists of the North Central OH Dental Society. This is a great opportunity for children who haven't had a dental check up for a year or more because their families lack the money or can't find a dentist to accept them. Help may be available for kids who are found to need treatment. Dental information & gift packets will also be given.

**To schedule** 419-668-1652 x 252 or 1-888-694-2443 x 252.

—Fisher Titus notification  
—Huron Co General Health

### **Did you know?**

The Smile Express full service mobile dental clinic is in Norwalk once a month!

Serves children and adults low cost payment Medicaid.

Call 1-866-694-2443 x 252

**Erie County Health Department**

**PUBLIC HEALTH OUTREACH CLINICS**

Services provided include child, adolescent, and adult vaccines; blood pressure screening; individual health assessments, which include lipid profile, blood glucose, hemoglobin A1C, and health risk assessment. (Please note: fasting 9-12 hours before testing is required for individual health assessments.) FREE lead testing for children 0-6 years of age is available. We provide referral source services, Community Outreach and Healthy Lifestyle education. For more information call ([419](tel:4196265623)) [626-5623](tel:4196265623) ext. 109. Visit the website: [www.eriecohealthohio.org](http://www.eriecohealthohio.org)

**PICTURE ID REQUIRED (Id of Parent/Guardian of Child)**

**IMMUNIZATION RECORDS REQUIRED FOR CHILDREN.**

A sliding fee scale will be applied as appropriate. Medicaid, Medicare, other insurances, and cash are accepted.

**At the Berlin Township Hall, 12101 State Rt. 61, on Tuesdays at 3 week intervals:**

- Feb. 8                      8-10 a.m.
- March 1 & 22              8-10 a.m.
- Apr. 12                      8-10 a.m.
- May 3 & 24                8-10 a.m.
- June 14 & 23              8-10 a.m.

—Linda Phillips/eriecohealthohio.org

## Crank It Up Fundraiser

**Bath & Body Works \$10**

Contribution: 13.00% to church

**Bath & Body Works \$25**

Contribution: 13.00% to church



**Applebee's \$25**

Contribution: 8.00% to church

**Applebee's \$50**

Contribution: 8.00% to church

**Bob Evans \$10**

Contribution: 10.00% to church



## Expecting the Unexpected

- “The coming of the Son of Man will be like a thief in the night.”

1 Thessalonians 5:2

- “But you, beloved, are not in darkness, for that time to surprise you like a thief.”

1 Thessalonians 5:4

- “Do not neglect to show hospitality to strangers, for by doing that some have entertained angels without knowing it.” Hebrews 13:2

- “Watch, therefore, for you know neither the day nor the hour in which Christ is coming.”

Matthew 25:13

When the water got to the farmer’s bottom windows, a neighbor rowed over to rescue him. The farmer declined: “I’m a man of faith. God will save me.”

When the waters rose to the second story windows, another neighbor appeared in a motor boat. Again the farmer refused to be rescued: “I’m a man of faith. God will save me.”

Finally the man sat on top of the roof. A helicopter few over and lowered a ladder. Once again, the farmer declined. “I’m a man of faith. I’m certain that God will save me.” The next thing he knew, the farmer found himself at the pearly gates. “What happened?” he moaned to St. Peter. “Why didn’t God save me?”

St. Peter shook his head sadly, saying, “Listen here, we sent a rowboat, a motor boat, and a helicopter!”

—Mission Moment ucc.org

<b>Boy Scouts of America incorporated</b>	1910
First <i>Boy Scout Handbook</i> published	1911
<i>Boys' Life</i> premiered	1911
<b>First Eagle Scout, Arthur R. Eldred</b>	1912
<i>Scouting</i> magazine premiered	1913
<b>Registration of Scouts began, 25¢ annual fee</b>	1913
Order of the Arrow began	1915
Federal charter granted by Congress	1916
First season at what would become Northern High Adventure Base	1923
<b>Boy Scout membership tops 1 million</b>	1925
Cub Scout program began	1930
Philmont donated to the BSA	1938
First BSA Wood Badge course taught	1948
First Pinewood Derby® held	1953
Webelos program added to Cub Scouting	1954
Exploring program began	1959
Florida National High Adventure Sea Base officially opened	1980
Tiger Cubs program added to Cub Scouting	1982
<b>1 millionth Eagle Scout, Alexander M. Holsinger</b>	1982
Learning for Life program began	1991
Venturing program began	1998
100 millionth member registered	2000
<b>2 millionth Eagle Scout, Anthony Thomas</b>	2009

**Membership\***

Total Cub Scouts	62,226,396
Total Boy Scouts/Venturers	52,077,933
<b>Total Youth Served</b>	<b>114,304,329</b>

Interesting  
Boy Scout  
Facts:

Boy Scout Day  
February 8, 2011



**B2 - BIT O' BLESSING BOX (Limited Quantities)**

**\$21** (plus sales tax where applicable)

- |   |                                     |                         |
|---|-------------------------------------|-------------------------|
| 3 lbs. Birds Eye Steamfresh Meals<br>(2 x 24 oz. pkgs.) | 2 lbs. Breaded Chicken Breast Bites | 20 oz. Shoestring Fries |
| 2 lbs. IQF Boneless Skinless Chicken Breasts            | 1 lb. 80/20 Ground Beef             | 7.5 oz. Skillet Meal    |
|   | 1 lb. Pinto Beans                   | 4 ea. Honey Buns        |
|   | 1 lb. Green Beans                   |                         |

**B1 - "BREAD OF LIFE" SIGNATURE BOX**

**\$31** (plus sales tax where applicable)

- |   |                                 |  |
|---|---------------------------------|--|
| 2 lbs. Hamburger Steaks (4 x 8 oz.)                 | 1 lb. Smoked Sausage            | 8 oz. Buttermilk Biscuit Mix             |
| 2 lbs. IQF Boneless Skinless Chicken Breast Fillets | 1 lb. Corn                      | 10 ct. Instant Oatmeal (2 x 5 ct. boxes) |
| 2 lbs. Macaroni & Beef Entrée                       | 1 lb. Green Beans               | 32 oz. Shelf-Stable 2% Milk              |
| 1 lb. Boneless Pork Chops (4 x 4 oz.)               | 1 lb. Sugar Snap Peas & Carrots | 1 Dozen Eggs                             |
| 1 lb. 80/20 Ground Beef                             | 15 oz. Diced Tomatoes           | 8 oz. Chocolate Chip Cookie Mix          |
| 1 lb. Bake or Fry Crunchy Fish Bites                | 1 lb. Kidney Beans              |  |
|   | 1 pkt. Chili Seasoning Mix      |  |

**B3 - BOUNTIFUL BLESSING BOX**

**\$41** (plus sales tax where applicable)

- |   |                                      |  |
|---|--------------------------------------|--|
| 2 lbs. Hamburger Steaks (4 x 8 oz.)                               | 1 lb. 80/20 Ground Beef              | 1 lb. Kidney Beans                       |
| 2 lbs. IQF Boneless Skinless Chicken Breast Fillets               | 1 lb. Bake or Fry Crunchy Fish Bites | 1 pkt. Chili Seasoning Mix               |
| 2 lbs. Macaroni & Beef Entrée                                     | 1 lb. Smoked Sausage                 | 8 oz. Buttermilk Biscuit Mix             |
| 2 lbs. Breaded Chicken Breast Chunks                              | 2 lbs. Cream of Broccoli Soup        | 7 oz. Apple Cinnamon Muffin Mix          |
| 1.5 lbs. Fully Cooked Salisbury Steaks (8 x 3 oz., without gravy) | 2 lbs. Tomato Basil Soup             | 10 ct. Instant Oatmeal (2 x 5 ct. boxes) |
| 1.5 lbs. (avg.) Tyson Natural Chicken Breast Tenderloins          | 24 oz. Natural Cut Fries             | 32 oz. Shelf-Stable 2% Milk              |
| 1 lb. Boneless Pork Chops (4 x 4 oz.)                             | 1 lb. Corn                           | 1 Dozen Eggs                             |
|   | 1 lb. Green Beans                    | 8 oz. Chocolate Chip Cookie Mix          |
|   | 1 lb. Sugar Snap Peas & Carrots      |  |
|   | 15 oz. Diced Tomatoes                |  |

**B4 - FAST & FLAVORFUL CUISINE**

**\$28** (plus sales tax where applicable)

*Convenience meals great for seniors and people on the go!*

- |                         |                             |                                     |
|-------------------------|-----------------------------|-------------------------------------|
| • Fettuccini Alfredo    | • White Chicken Tetrazzini  | • BBQ White Chicken                 |
| • Fish Sticks           | • Pot Roast with Vegetables | • White Chicken and Gravy           |
| • Roasted White Chicken | • White Chicken Cacciatore  | (Blended with Mushrooms and Onions) |
| • Sweet and Sour Pork   | • Country Steak with Gravy  |                                     |

**GLUTEN FREE! B5 - ALLERGEN FREE FOOD BOX \$25**

(plus sales tax where applicable)

- |                                      |                                      |                           |
|--------------------------------------|--------------------------------------|---------------------------|
| 1 lb. Breaded Chicken Breast Nuggets | 1 lb. Breaded Breast Fillet Patties  | 1 lb. Breaded Cubed Steak |
| 1 lb. Breaded Chicken Tenderloins    | 1 lb. Breaded Boneless Chicken Wings |                           |

**B6 - JUST 4 ME - AFTER SCHOOL BOX**

**\$24** (plus sales tax where applicable)

- |   |  |   |
|---|--|---|
| 2 lbs. Fully Cooked Breaded Chicken Breast Pieces | 2 ea. 10 oz. Fully Cooked Mac & Cheese Pouches | 2 pkgs. PB&J Graham Cracker Wafers          |
| 1.5 lbs. Mini Corn Dogs                           | 2 ea. 3 oz. Grilled Cheese Sandwich            | 1 pkg. 4.75 oz. Pancakes & Sausage          |
| 4 ea. 2.8 oz. Peanut Butter and Jelly Jamwich     | 1 pk. Twin Breaded Chicken Sandwiches          | 2 ea. 3.4 oz. Watermelon Italian Ice        |
|   | 1 pkg. Pizza Bites                             | 2 ea. 3.2 oz. Raspberry Fruit Juice Sherbet |

**B7 - JUST 4 ME - NO CHILD GOES WITHOUT**

**\$24** (plus sales tax where applicable)

- |   |                                  |   |
|---|----------------------------------|---|
| 10 ct. Instant Oatmeal (2 x 5ct. Boxes) | 7.5 oz. Noodle Rings & Chicken   | 1 ea. Chunk Lite Tuna in Water (.5 oz.)       |
| 7.5 oz. Beans & Wieners                 | 7.5 oz. Cheezy Mac 'n Franks     | 1 ea. Valley Fresh All White Chicken (.5 oz.) |
| 7.5 oz. Cheezy Mac 'n Cheese            | 7 ea. Cereal Bowls (.75 oz. ea.) | 6 pk. Applesauce                              |
| 7.5 oz. Mini Beef Ravioli               | 1 ea. Peanut Butter (12 oz.)     | 5 ea. Granola Bars (.25 oz. ea.)              |
| 7.5 oz. Spaghetti and Mini Meatballs    | 1 ea. Pure Honey (12 oz.)        | 32 oz. Shelf-Stable 2% Milk                   |

**B8 - JUST 4 ME - FRUIT AND VEGGIE**

**\$16** (plus sales tax where applicable)

- |                           |                  |                             |
|---------------------------|------------------|-----------------------------|
| 3 ea. Red Apples          | 3 ea. Pears      | 1 lb. Mini CA Cello Carrots |
| 3 ea. Granny Smith Apples | 6-pk. Applesauce | 1 stalk CA Sleeved Celery   |
| 3 ea. Navel Oranges       | 6-pk. Raisins    | 3 ct. Microwave Popcorn     |

**S1 - FEBRUARY SPECIAL #1 \$25\***

- 4 lb. Steak Special**  
4 lbs. Black Angus Sirloin Steaks (8 x 8 oz.)

**S2 - FEBRUARY SPECIAL #2 \$18\***

- 10 lb. Chicken Special**  
10 lbs. Breaded Chicken Breast Chunks

\*plus sales tax where applicable

*Please see our website for online-only specials*

**S3 - FEBRUARY SPECIAL #3 \$23\***

- 3 lb. bag Juice Oranges  
3 lb. bag Tangerines  
2 ea. Pink Grapefruit  
1 ea. Golden Ripe Pineapple  
1 ea. Mango  
1 ea. Avocado  
4 ea. Red Apples  
1 lb. bag Kiwi  
3 lb. bag Idaho Potatoes  
3 lb. bag Sweet Potatoes  
2 lb. bag Yellow Onions  
1 head Green Cabbage  
1 Fruit and Veggie Recipe Sheet

## **Angel Food**

**Order Date:** Wednesday, February 9, 2011 11am-1pm BHCC

**Church Office:** First Congregational UCC PO Box 66, 5 E. Main St., BH 44184  
419-588-2102

**Distribution Date:** Saturday, February 20, 2011 10am BHCC

## **Blessings by the Box**

Angel Food is available in a quantity that can fit into a medium-sized box at \$31—\$41 per unit. Each month's menu is different than the previous month and consists of both fresh and frozen items with an average retail value of approximately \$60.

Comparison shopping has been done across the country in various communities using a wide range of retail grocery stores and has resulted in the same food items costing from between \$42 and \$78.

Generally, one unit of food assists in feeding a family of four for about one week or a single senior citizen for almost a month. The food is all the same high quality one could purchase at a grocery store. There are no second-hand items, no damaged or out-dated goods, no dented cans without labels, no day-old breads and no produce that is almost too ripe.

**There are no qualifications, minimums, income restrictions, or applications.**

Everyone is encouraged to participate. Some churches even encourage participants to apply the money they saved to help someone else in need.

—Women's Fellowship / Host Church for Angel Food Ministry

## **Fisher-Titus Medical Center**

### **Health Ministry Program**

#### **February is AMD month.**

“The initials AMD stand for a disorder called age-related macular degeneration. AMD is a disease that affects part of the back of the eye called the macula, the central part of the retina.”

([www.preventblindness.org](http://www.preventblindness.org)). AMD is the leading cause of vision loss in people over 65 years of age.

**Signs and Symptoms of AMD:** straight lines such as telephone poles appear wavy. Reading material appears blurry and you notice dark or empty spots in the center of your vision.

**Treatment for AMD-** treatments available such as laser treatments may help slow down the progression of AMD, if you are diagnosed with AMD your eye doctor will tell you your treatment options.

**Lower your risk of eye disease by:** avoid smoking, eat healthy foods and stay active, control your blood pressure and protect your eyes from the sun.

If you are 65 years or older you should visit your eye doctor regularly (every 1-2 years) and have a complete dilated eye exam. Under 65 years old you should have an eye exam every 2-4 years, sooner if you are having problems.

***“Do not be wise in your own eyes; fear the Lord and depart from evil. It will be health to your flesh, and strength to your bones.”*** ***—Proverbs 3:7,8.***

***—Jill Schafer, RN—Health Ministry Program***

***—Deb Oehling***

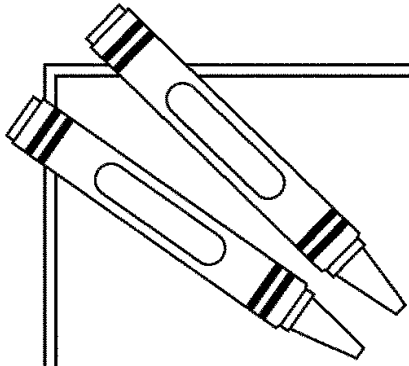

# Just for **KIDS**

## 1 Thessalonians 5:16-18

The letters of the words in the verse have been started for you. Add a straight line to each to complete the letters.

Read the words.

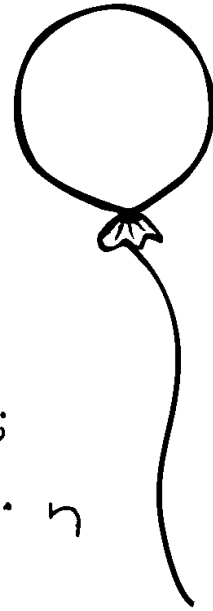
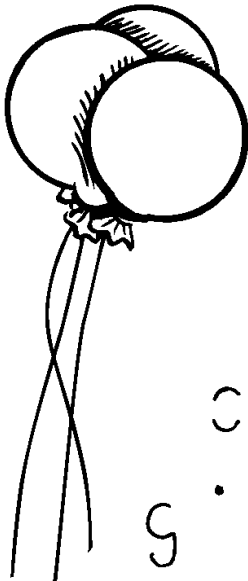

Be joyful  
at all times;  
pray  
continually;  
give thanks in  
all circumstances,  
for this is  
God's will for you  
in Christ—Jesus.

**Our copier** has seen its final days. We are seeking donations for a new copier at a cost of \$6,000. We have had a substantial donation, but need a little more to finish the project. If you'd like to support this project contact a trustee.

—John Hartman reported on January 16, 2011

### **Chocolate.....Lovers.....**

mark your calendar  
for Women's Fellowships

### **Chocolate Party**

**March 1, 2011 Fowler room.**

Bring a favorite food item to dip in chocolate.

—Women's Fellowship  
Pauline Malone

### **February Birthdays and Anniversaries**

Feb. 1 David Shupe  
Feb. 2 Mary Leber  
Feb. 3 Kirsten Grech  
Feb. 3 Nicholas Shupe  
Feb. 3 Jennifer Lindner  
Feb. 6 Tricia DeMuth  
Feb. 7 Leroy Hayes  
Feb. 9 Adam Link  
Feb. 10 Lauren Taira  
Feb. 11 Serena Frausto  
Feb. 14 John & Pat Carson  
Feb. 17 Jackie Gammie  
Feb. 19 David Ratti  
Feb. 21 Trent Wikel  
Feb. 21 Ron Lindner  
Feb. 24 Dale Land  
Feb. 25 Bob Malone Jr.  
Feb. 26 Monica Klarer  
Feb. 26 Randy Deehr  
Feb. 26 Richard Malone  
Feb. 27 Melanne Lindner  
Feb. 28 Ben Gammie

**Church e-mail:**

[bhcong@frontier.com](mailto:bhcong@frontier.com)

**If you looking to serve the church,**

consider signing up or contact a

member of Diaconate for the

following:

**Liturgist (Sandy Shively)**

**Acolyte (Kirsten Grech)**

**Children's Story (Roger Wallace)**

**Nursery (Alexis**

**Burnham and Diane Willis)**

**Fellowship Hour (Bill Deehr)**

:

First Congregational Church and Society

United Church of Christ

Reverend Gary Proietti

5 E. Main Street

P.O. Box 66

Berlin Heights, OH 44814

419-588-2102



**Feb. 6** Ushers: Bill Deehr, Tom Holland  
 Diane Willis, Kirsten Grech  
 Acolytes: Natalie Beaty  
 Liturgist:  
 Children's Story: Rev. Gary Proiette  
 Nursery:  
 Coffee Host: Family Potluck/Games

**Feb. 13** Ushers: Bill Deehr, Tom Holland  
 Diane Willis, Kirsten Grech  
 Acolytes: James Hill  
 Liturgist: Connie Deehr  
 Children's Story: Bob Bement  
 Nursery:  
 Coffee Host: Bob & Barb Bement

**W  
O  
R  
S  
H  
I  
P**

**L  
E  
A  
D  
E  
R  
S**

W  
O  
R  
S  
H  
I  
P  
  
L  
E  
A  
D  
E  
R  
S

<b>Feb. 20</b>	Ushers:	Bill Deehr Tom Holland
Women's		Diane Willis Kristen Grech
Sunday	Acolytes:	Reilly Mullen
	Liturgist:	Women's Sunday
	Children's Story:	Barb Bement
	Nursery:	
	Coffee Hosts:	John & Kay Hartman
<b>Feb. 27</b>	Ushers:	Bill Deehr Tom Holland
		Diane Willis Kirsten Grech
Point of Light	Acolytes:	Garryn Snyder
	Liturgist:	
10th	Children's Story:	Becky Coleman
Anniversary	Nursery:	
	Coffee Hosts:	Point of Light

**Family Fun Sunday**

**February 6th**

**11:30am Pot Luck**

Bring a dish to share and  
tableware.

Beverages will be provided.

Bring your favorite game  
to play.

—Women's Fellowship